



厦门友盟电子有限公司

XIAMEN UME ELECTRONICS CO., LTD.

产品规格承认书 SPECIFICATION

文件编号 File No.: UME-EG-SP16111401/A1

客户 Customer	AKON	核准 Approval	JB
品名 Product	开关电源 Switching power supply	品管确认 QC	LTF
型号 Model	AD-P50P200	审核 Check	ZL
日期 Date	2022-06-29	拟制 Execution	BMD

客户承认意见 Confirmation by Customer	客户签署 Stamp & Signature
<input type="checkbox"/> 合格 Accept	
<input type="checkbox"/> 不合格 Reject	
<input type="checkbox"/> 条件合格 Conditional Acceptance	

确认签署后，请回传一份。有任何问题，请尽快告知我们。

Please return one copy to us with your signature and feel free to contact us for any questions.

厦门友盟电子有限公司

XIAMEN UME ELECTRONICS CO., LTD.

电话 Tel:0592-2611448

地址:厦门湖里区殿前一路536号

Add:NO. 536 Dianqian YiLu, Huli District, Xiamen.



产品规格承认书 SPECIFICATION				文件编号 File No.	UME-EG-SP16111401/A1
品名 Product	开关电源 SPS	型号 Model	AD-P50P200	日期 Date	2022-06-29

目录 INDEX

1	变更履历 Revision History.....	1-3
2	概述 Summary	2-4
3	技术要求 Technical requirements.....	3-4
3.1	安全标准和认证证书 Safety Standards and Certificate number	3-4
3.2	Input	3-4
3.3	Output.....	3-4
3.4	可靠性及质量控制 Reliability and Quality Control.....	3-5
3.5	测试线路图 Test Circuit.....	3-9
4	线路图 Schematic Diagram	4-9
5	电路板图 P.C.B.....	5-10
6	Cord (单位 unit: mm 颜色 color: BK)	6-11
7	外观示意图 Mechanical Drawing (单位 unit: mm 颜色 color: BK)	7-12
8	铭板标识 Label.....	8-13
9	包装方式 Packaging	9-13
10	BOM list.....	10-14

*** The products limited warranty period is 18 months.
(From date code of product.)**

*** The products meet RoHS requirements.**

批准 Approval:	J6	审核 Check:	ZL	制表 Execution:	BMD
-----------------	----	-----------	----	---------------	-----



产品规格承认书 SPECIFICATION				文件编号 File No.	UME-EG-SP16111401/A1
品名 Product	开关电源 SPS	型号 Model	AD-P50P200	日期 Date	2022-06-29

2 概述 Summary

2.1 本文件包含一般的客户要求及电气、机构和安全性能等方面的描述。

This document contains general customer requirements and those of specific electrical, mechanical and safety for this product.

3 技术要求 Technical requirements

3.1 安全标准和认证证书 Safety Standards and Certificate number

Japan: 电气用品安全法别表第八【JET6108-61010-1011】

3.2 Input

Rated Input Voltage	100-240Vac
Operating Range	90-264Vac
Rated Input Frequency	50/60Hz
Rated Input Current	0.3A
Input Power (No Load)	0.1W Max
Primary Current Protection	Over current protection: Electric current fuse

3.3 Output

Rated Dc Output Voltage	5.5V Max	No Load
	5.0V ± 5%	Load 2000mA
Over Current Protection	2.6A Max @ Vin=100Vac/240Vac	
Line Regulation	The line regulation is less than ±1% while measuring at rated load and ±5% of input voltage changing	
Ripple	≤ 200mVp-p	
Switching Efficiency	78.7% minimum @ input 115AC/230VAC to meet DOE6	
DC Plug	Φ 2.1*5.5*9.5mm	
DC Cord	22AWG 2464 L = 1500mm, black Lead-free soldering	

批准 Approval:	J6	审核 Check:	ZL	制表 Execution:	BMD
-----------------	----	-----------	----	---------------	-----



产品规格承认书 SPECIFICATION				文件编号 File No.	UME-EG-SP16111401/A1
品名 Product	开关电源 SPS	型号 Model	AD-P50P200	日期 Date	2022-06-29

3.4 可靠性及质量控制 Reliability and Quality Control

【Electrical Test Items】

Item		Conditions	Criteria
1	Leakage Current	Measure the leakage current between Primary and Secondary when adding rated input. AC input = Rating voltage (100/240V)	Less than 250 μ A
2	ESD Test	1.Test is conducted at room temperature/humidity.(25 $^{\circ}$ C, RH 50-60%) 2.Test set is 150pF/150 Ω . 3.(1) \pm 4KV:Contact discharge test. +phase: 3times, -phase: 3times, total: 6times. (2) \pm 8KV:Air discharge test. +phase : 3times, -phase: 3times, total: 6times. (Note) After each ESD test, it should be discharged.	No malfunction (must be in spec after test).
		1.Test is conducted at room temperature/humidity.(25 $^{\circ}$ C, RH 50-60%) 2.Test set is 150pF/150 Ω . 3.(1) \pm 6KV:Contact discharge test. + phase: 3times, -phase: 3times total: 6times. (2) \pm 10KV:Air discharge test. + phase: 3times, -phase: 3times, total: 6times. (Note)After each ESD test, it should be discharged.	No destruction
	ESD Test (Ability test)	1.Test is conducted at room temperature/humidity.(25 $^{\circ}$ C, RH 50-60%) 2.Test condition: 150pF/150 Ω . 3,Contact discharge / Air discharge 4,Load: 1)no load 2)rated load 5. Impressing 10 times continuously to plus and minus each. 6,Discharging once after impressing 10 times (To confirm the capacity of unit up to the unit destroyed)	It confirms at which voltage value the adapter breaks.(Note: Not part of qualification)
3	Hi-POT test	Condition=AC3000V, 1min. Test place=Between AC blade and DC plug Sensitivity current=10mA	No malfunction. (damage, arc, breakdown etc)
4	Insulation resistance	DC500V, 1min. Between AC blade and DC plug	More than 100M Ω
5	Temperature Rise Test	1.Apply rating input voltage(100/240V), 2.Load: Charge actual Cellular phone 3.Measure the surface temperature of the adaptor 4.T ambient = The room temperature 5.Condition: Until it carries out temperature saturation (the definition of temperature than 1 $^{\circ}$ C in 1 hour).	Housing surface Temperature rise is less than 45K.

批准 Approval:	J6	审核 Check:	ZL	制表 Execution:	BMD
-----------------	----	-----------	----	---------------	-----



产品规格承认书 SPECIFICATION				文件编号 File No.	UME-EG-SP16111401/A1
品名 Product	开关电源 SPS	型号 Model	AD-P50P200	日期 Date	2022-06-29

		1.Apply rating input voltage(100/240V), 2.No Load 3.Measure the surface temperature of the adaptor	Housing surface Temperature rise is less than 15K.
6	Input over / under	Apply voltage=(rating input voltage)x(1±30%) Impressed time : 24h	No destruction
7	EMI/Conducted Emission	Telephone stand by mode with rapid-charge condition	Conform to: FCC 47CFR Part 15 Class B (for US) EN55022 (For Japan)
8	Surge	IEC61000-4-5 1.2×50μs 1.0KV Positive and negative all three times, Current limiting impedance 100 Ω, Time interval 30 seconds min.	No destruction.

【Environmental Test Items】

Item	Conditions	Criteria
1	Temperature range Electrical performance guarantees temperature range: 0℃ to 40℃ Electrical performance not guarantees working temperature range: -20℃ to 50℃ Storage temperature range: -30℃ to 80℃	No abnormal appearance, mechanic performance or electric performance
2	High Temperature Leave 1. Temperature 80℃ for 96 hours. 2. After that test, test set is left in normal temperature, humidity condition for more than 1hour, then evaluate.	No abnormal appearance, mechanic performance or electric performance
3	Low Temperature Leave 1. Temperature -30℃ for 96 hours. 2. After that test, test set is left in normal temperature, humidity condition more than 1(hour), then evaluate.	
4	High Temperature Humidity 1. Temperature 50℃, air moisture 90-95% RH for 96 hours. 2. After that test, test set is left in normal temperature, humidity condition more than 30min, then evaluate.	
5	Temperature Humidity test 1. Temperature 40℃, air moisture 90-95% RH for 96 hours. 2. After that test, test set is left in normal temperature, humidity condition more than 30min, then evaluate.	
6	Heat Shock Test 1. Condition: -30℃/ 1 hour to +80℃/ 1 hour, 60 cycles 2. After that test, test set is left in normal temperature, humidity condition more than 1 hour, then evaluate.	

批准 Approval:	J6	审核 Check:	ZL	制表 Execution:	BMD
-----------------	----	-----------	----	---------------	-----



产品规格承认书 SPECIFICATION				文件编号 File No.	UME-EG-SP16111401/A1
品名 Product	开关电源 SPS	型号 Model	AD-P50P200	日期 Date	2022-06-29

7	Heat/humidity Cycle Test	<p>A, C, D : RH=90 ± 10% B : RH= 90 ± 5% E : No limit After 5cycles, put EUT at room temperature/humidity condition</p>			
8	Humidity	Operation is 10~85%. Storages is 5~95%			Non-condensing

【Mechanical Test Items】

Item	Conditions	Criteria	
1	Drop Test	No parts remove, no abnormal mechanic performance, (outside scratches are acceptable)	
2	Package Drop Test		
3	Unit Vibration Test		
4	Package Vibration		
5	AC Plug in/out Test (AC Blade part)		
6	Exfoliate with cellophane tape and examine it	A character do not disappear.	
7	The reliability to face each other to come off	① -40℃ ② 80℃ ③ 50℃ 90% Each 96 hours ④ ③ After, it is a thermal shock examination	Don't take the label off the main body

批准 Approval:	J6	审核 Check:	ZL	制表 Execution:	BMD
-----------------	----	-----------	----	---------------	-----



产品规格承认书 SPECIFICATION				文件编号 File No.	UME-EG-SP16111401/A1
品名 Product	开关电源 SPS	型号 Model	AD-P50P200	日期 Date	2022-06-29

	the label	of 96 cycles	
8	No tally part step	Difference of the pitch by height differences of the tally part between casts	less than 0.25mm after an environmental examination

【DC cord Test Items】

Item	Conditions	Criteria
1	DC Cord strength (adaptor side / plug side) 1. Test part: Between adaptor and DC cord 2. Pull a cord with 49N(5Kgf) force 3. Time: 1min.	No abnormality such as wire cut, bushing come off
2	DC Cord Bending Test (adaptor side / plug side) Weight = 4.9N(500g) Angle = +/-90° Cycles in every minute = 40times/min. Test cycles = 1000times Note: contrarotate 90°, and then rotate it clockwise with 180° (+90° ~-90°), and at last return to origin. (1 Cycle : 0° ⇒ -90° ⇒ 0° ⇒ +90° ⇒ 0°)	Operate properly.

【Safety Test Items】

1	MTBF	Make a measurement condition, a calculation standard clear	More than 50,000 hours
2	Part materials	It is maintenance or the incombustibility of contact / part materials approaching it in an outer fence, the charge department of the electric part	same as UL94V-0; more than it
3	print board	Incombustibility	same as UL94V-0; more than it
4	No tally part step	Difference of the pitch by height differences of the tally part between casts	less than 0.25mm after an environmental examination

批准 Approval:	J6	审核 Check:	ZL	制表 Execution:	BMD
-----------------	----	-----------	----	---------------	-----



产品规格承认书 SPECIFICATION				文件编号 File No.	UME-EG-SP16111401/A1
品名 Product	开关电源 SPS	型号 Model	AD-P50P200	日期 Date	2022-06-29

3.5 测试线路图 Test Circuit

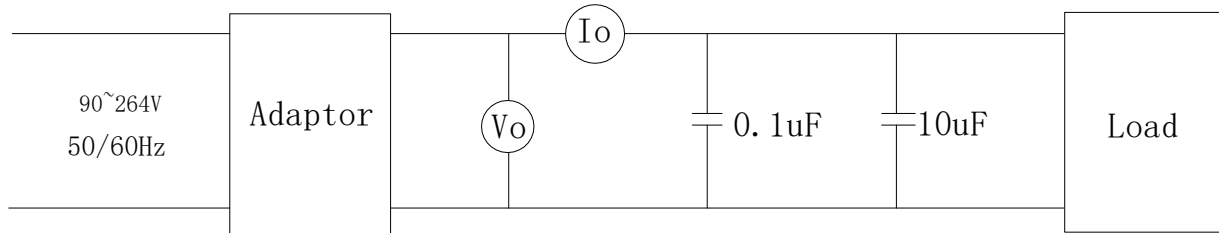

4 线路图 Schematic Diagram

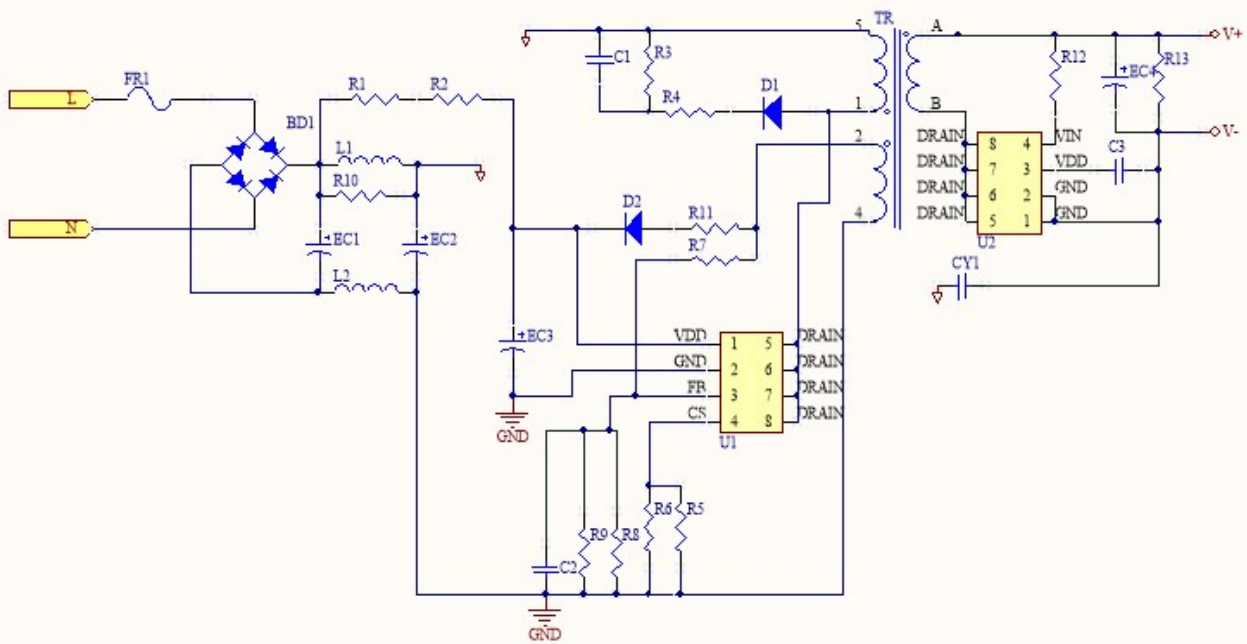

批准 Approval:	J6	审核 Check:	ZL	制表 Execution:	BMD
-----------------	----	-----------	----	---------------	-----



产品规格承认书 SPECIFICATION				文件编号 File No.	UME-EG-SP16111401/A1
品名 Product	开关电源 SPS	型号 Model	AD-P50P200	日期 Date	2022-06-29

5 电路板图 P.C.B

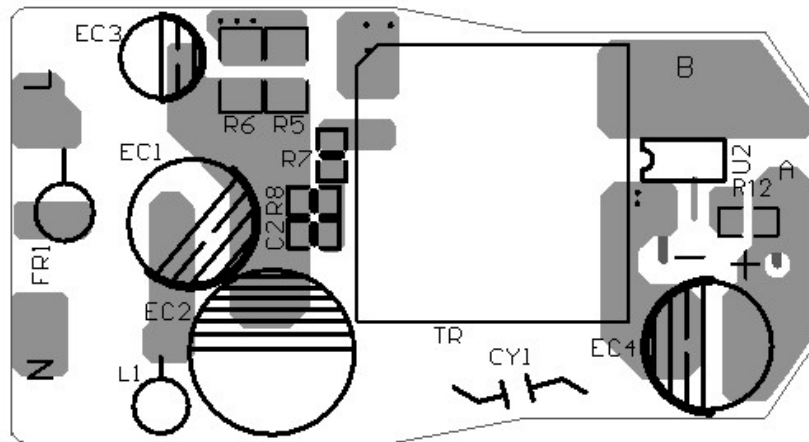
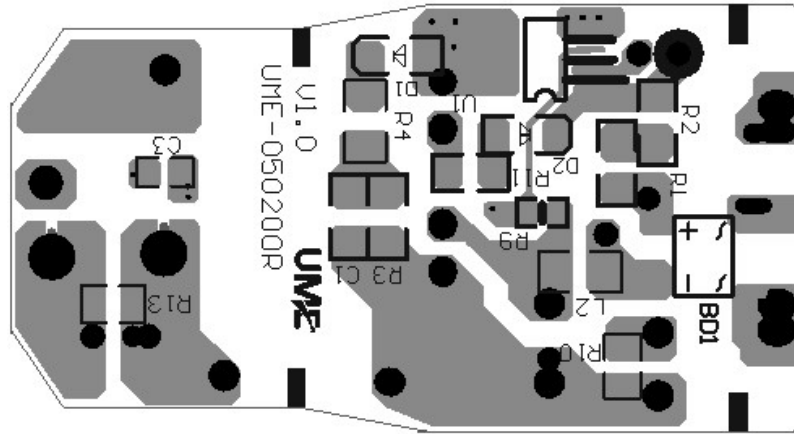

批准 Approval:	J6	审核 Check:	ZL	制表 Execution:	BMD
-----------------	----	-----------	----	---------------	-----



产品规格承认书 SPECIFICATION				文件编号 File No.	UME-EG-SP16111401/A1
品名 Product	开关电源 SPS	型号 Model	AD-P50P200	日期 Date	2022-06-29

6 Cord (单位 unit: mm 颜色 color: BK)

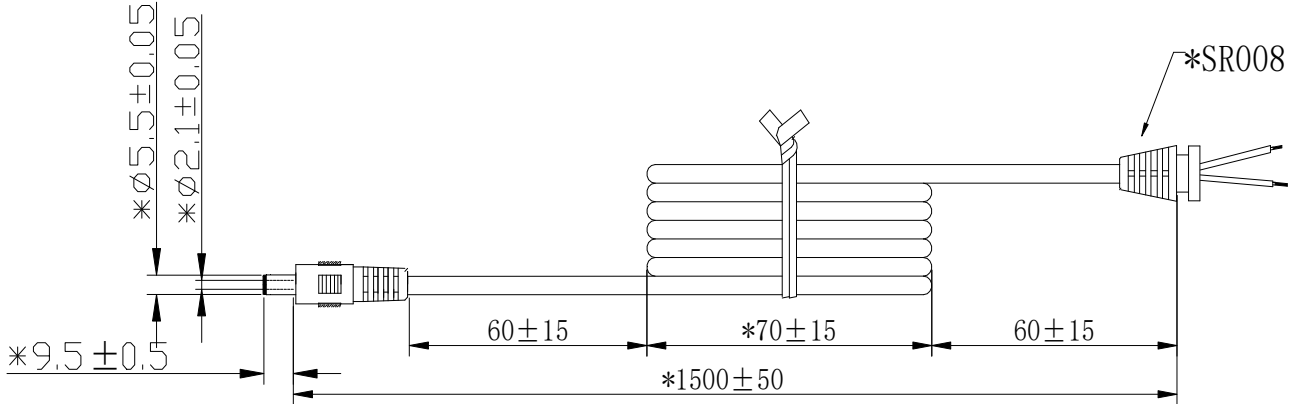

备注:

1. 导线规格: 22AWG 2464 音叉型 外被黑色圆线, 芯线颜色: 红色+黑色, 导线总长1500mm; 材质符合RoHS要求。导线按图示尺寸捆扎、测试, 导线间应开路, 对应线头线尾应短路导通, 极性连接正确;
2. 两头剥线焊锡, 剥线长度3mm+1/-0。剥线要求如图所示, 剥丝线焊锡的直径为1.15mm MAX, 外露导线须全焊。接线方式: 红色芯线接PIN中心, 黑色芯线接外侧, PG头成型, SR-008成型; SR008尺寸为7*4.8mm.
3. SR拉力测试: 吊重1Kg/10分钟, 不可有位移, 吊重5Kg/1分钟, 位移2mmMAX
4. 插拔力测试: 插入力2KgMAX, 拔出力0.3KgMIN; 插拔6000MIN次不允许有电气和机械性能的损坏, 且满足拔出力0.1KgMIN;
5. 摇摆测试: 吊重500g, 以40次/分作90° 往返, 每一往返为一次, 至少1000次;
6. PLUG绝缘阻抗测试: 100M Ω MIN在500DC/分; PLUG接触阻抗测试: 100m Ω MAX;
7. 导线, SR, PLUG非移行性依据厂内一般进行; 禁止使用VDE所禁用的物质。
8. 打*号尺寸, 为入料检查项目;

批准 Approval:	J6	审核 Check:	ZL	制表 Execution:	BMD
-----------------	----	-----------	----	---------------	-----



产品规格承认书 SPECIFICATION				文件编号 File No.	UME-EG-SP16111401/A1
品名 Product	开关电源 SPS	型号 Model	AD-P50P200	日期 Date	2022-06-29

7 外观示意图 Mechanical Drawing (单位 unit: mm 颜色 color: BK)

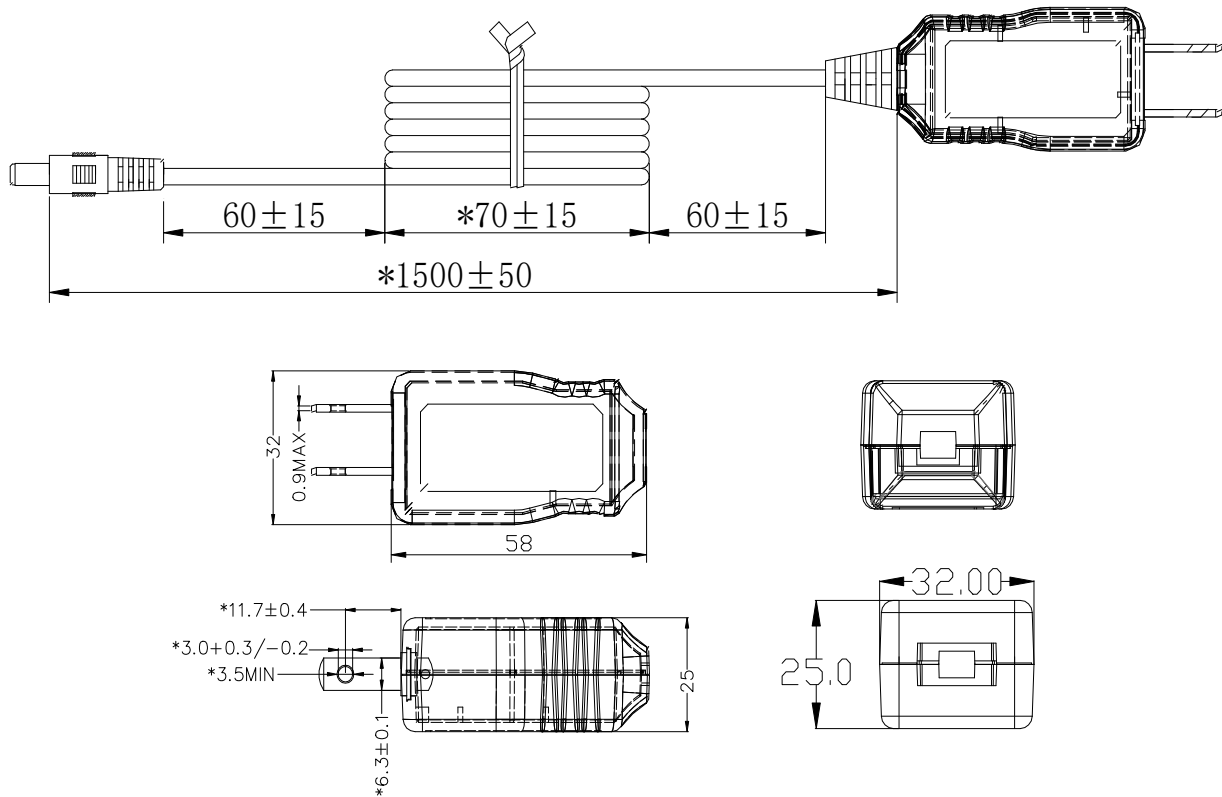

批准 Approval:	J6	审核 Check:	ZL	制表 Execution:	BMD
-----------------	----	-----------	----	---------------	-----



产品规格承认书 SPECIFICATION				文件编号 File No.	UME-EG-SP16111401/A1
品名 Product	开关电源 SPS	型号 Model	AD-P50P200	日期 Date	2022-06-29

8 铭板标识 Label

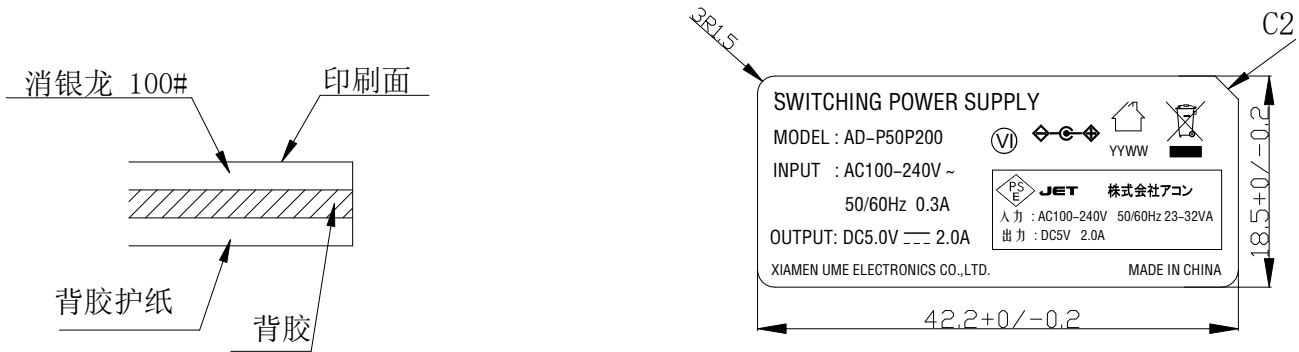

备注:

1. 材质: 消银龙 100# (铭板基材厚度0.1mm, 材质PET)。
2. 黑底银字, 亚膜, 印刷参照ARTWORK, 印刷位置居中。
3. 背胶: 高冠DT#。
4. 密着性: 将铭板贴于实际CASE上, 在-40° C下放置48小时, 再放入75° C, 90%RH下放置48小时后, 于常温常湿下放1小时, 在铭板长度方向上贴上强力胶带(3M NO. 610 18mm宽或等价物), 以垂直方向急速拉起, 铭板不能有起泡或脱落。
5. 粘着力: 依据铭板检验标准测试。
6. YY表示年份, WW表示周期, 年周依订单要求或实际生产日而定。
7. 字体清晰可读, 布局居中, 字体或图案与铭板边缘距离大于0.4mm。
8. 铭板字体为方正姚体。



9 包装方式 Packaging

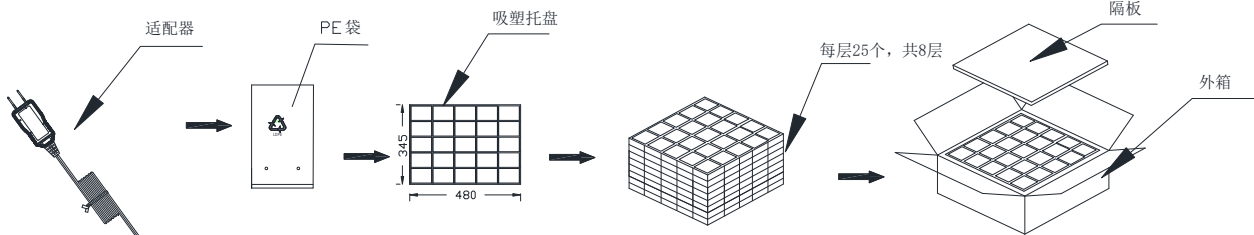

批准 Approval:	J6	审核 Check:	ZL	制表 Execution:	BMD
-----------------	----	-----------	----	---------------	-----



产品规格承认书 SPECIFICATION				文件编号 File No.	UME-EG-SP16111401/A1
品名 Product	开关电源 SPS	型号 Model	AD-P50P200	日期 Date	2022-06-29

10 BOM list

NO.	ITEM	DESCRIPTION	SPECIFICATION	QTY	MANUFACTURER
1	PCB	PCB	UME-050200R-PCB	1	TengShengXing/HG
2	L2	CHIP L	10uH±10% 1206	1	Taiqing/Fenghua
3	R1,R2	CHIP R	1.5MΩ±5% 1206	2	YAGEO/FENG HUA
4	R3	CHIP R	300KΩ±5% 1206	1	YAGEO/FENG HUA
5	R4	CHIP R	100Ω±5% 1206	1	YAGEO/FENG HUA
6	R5,R6	CHIP R	2Ω±1% 1206	2	YAGEO/FENG HUA
7	R7	CHIP R	27KΩ±1% 0603	1	YAGEO/FENG HUA
8	R8	CHIP R	7.5KΩ±1% 0603	1	YAGEO/FENG HUA
9	R9	CHIP R	36KΩ±1% 0603	1	YAGEO/FENG HUA
10	R10	CHIP R	4.7KΩ±5% 0805	1	YAGEO/FENG HUA
11	R11	CHIP R	4.7Ω±5% 0805	1	YAGEO/FENG HUA
12	R12	CHIP R	22Ω±5% 0603	1	YAGEO/FENG HUA
13	R13	CHIP R	1.5KΩ±5% 0805	1	YAGEO/FENG HUA
14	C1	CHIP R	471 500V±10% 1206 X7R	1	YAGEO/FENG HUA
15	C2	CHIP R	22PF 50V 0603 COG	1	YAGEO/FENG HUA
16	C3	CHIP C	105 16V±10% 0603 X7R	1	YAGEO/FENG HUA
19	D1,D2	CHIP D	A7 1A/1000V/SOD-123	2	JF/XH
21	BD1	Bridge Diode	ABS8 800V 1A	1	JF/XH
22	U1	IC	OB2573Y SO-8	1	OB
23	U2	IC	OB2005VK SO-8	1	OB
24	L1	Inductor	0512-470uH±10% 150mA	1	HXH/CHSH/ZY
25	CY1	Y cap	Y1 102 400V±20% P=10mm	1	STE/HJ
27	FR1	Fuse	T2A/250VAC 3.75*10mm	1	XC/SUNNY/Little fuse
28	EC1	E cap	10uF 400V±20% 105℃ Φ8*16mm(AX)	1	RUBYCON
29	EC2	E cap	10uF 400V±20% 105℃ Φ10*16mm(BXC)	1	RUBYCON
30	EC3	E cap	4.7uF 50V±20% 105℃ Φ5*11mm(YXF)	1	RUBYCON
		E cap	4.7uF 50V±20% 105℃ Φ5*11mm(YXJ)		RUBYCON

批准 Approval:	J6	审核 Check:	ZL	制表 Execution:	BMD
-----------------	----	-----------	----	---------------	-----



产品规格承认书 SPECIFICATION				文件编号 File No.	UME-EG-SP16111401/A1
品名 Product	开关电源 SPS	型号 Model	AD-P50P200	日期 Date	2022-06-29

31	EC4	E cap	1000uF 6.3V±20% 105℃ Φ6.3*10mm(PZ)	1	AISHI
32	TR1	TRANSFMOR	TR-050200S3 EE16	1	HXH/ ZY
33	FR1,L1	Tube	5mm 125℃(UL)	2	Woer/Sanlian
34	CASE	CASE	A02-A BK	1	JLF/YGE
35	CASE	CASE	A02-B BK	1	JLF/YGE
36	L,N	Connector	14.2*2.4*0.3mm CONT-01	2	Xiezhun
37	BLD	Blade	BLD-011(PSE) BK	1	GuanQiao/Yu'o
38	DC cord	Cable	2.1*5.5*9.5 22AWG L:1500mm 2464 BK	1	DPK/GC/Kaibo
39	NAP	NAP	NAP-050200F2-PSE	1	Yihangxin /JinXin
40	NAP	NAP	NAP-050101K-PSE-02B	1	Yihangxin /JinXin
41		PE BAG	150*100*4.0C	1	Xincheng
42		CARTON	490*356*240mm BIN-050080H	0.005	XinRuicheng/ FuXing
43		partition	485*350*3mm	0.005	XinRuicheng/ FuXing
44		plastic tray	480*345*30mm PVC	0.04	DaChengSuJiao
45		UL glue	UL UB-100	0.8g	U-Bond
46		Solder Bar	0.3Ag 0.7Cu 99Sn	0.4g	Yun Nan Tin
47		Solder wire	1Cu 99Sn	0.1g	Yun Nan Tin

批准 Approval:	J6	审核 Check:	ZL	制表 Execution:	BMD
-----------------	----	-----------	----	---------------	-----